

Liquid Line Filter Driers

MARS SERIES **201**



MARS Liquid Line Filter Driers

The MARS Liquid Line Filter Driers are designed to offer complete protection of your refrigerant system. The desiccant block is a carefully selected blend of molecular sieve and activated alumina, providing for maximum removal of moisture, acid, and foreign materials. This molded desiccant block allows for efficient filtration and retention of solid contaminants, while insuring minimum pressure drop. The solid molded block exposes maximum surface area and provides even distribution of filtered material as the refrigerant flows through the drier. These driers are intended for use on R-134A, R-404A, R-410A, R-507, R-12, R-500, R-502

Features & Benefits:

- High moisture removal
- High organic & inorganic acid removal
- Solid block desiccant core
- For use with HCFCs, CFCs, and the lubricants that go with them
- Nickel plated SAE flare and solid copper ODF fittings
- Corrosion resistant
- Maximum working pressure 600 PSIG
- Minimum burst pressure 2500 PSIG
- UL & CSA listed

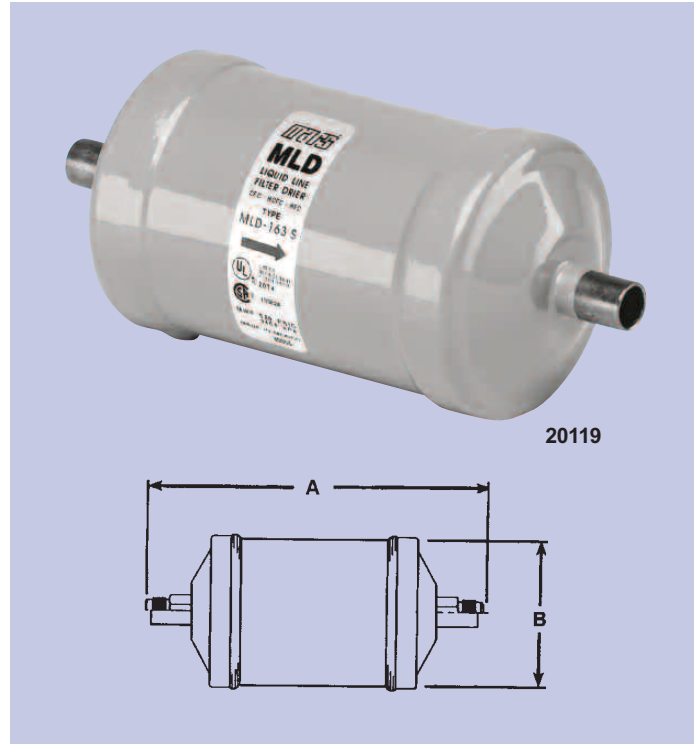

SERVICE & INSTALLATION

MARS NO.	MODEL NO.	CONNECTIONS SIZE & TYPE	DIMENSIONS		Flow Capacity ¹ Tons @ 1 PSI			CASE QTY.
			A	B	R-134A	R-22/R410A	R404A/R507	
20106	MLD-032	1/4 SAE	4.32	1.63	2.0	1.9	1.2	12
20107	MLD-032S	1/4 ODF	3.76	1.63	3.0	2.8	1.8	12
20108	MLD-052	1/4 SAE	4.88	2.50	2.1	2.0	1.3	12
20109	MLD-052S	1/4 ODF	4.33	2.50	3.0	2.9	1.9	12
20111	MLD-053S	3/8 ODF	4.53	2.50	6.0	5.8	3.8	12
20112	MLD-082	1/4 SAE	5.80	2.50	2.1	2.1	1.3	12
20113	MLD-082S	1/4 ODF	5.24	2.50	3.1	3.0	1.9	12
20114	MLD-083	3/8 SAE	6.10	2.50	4.9	4.7	3.0	12
20115	MLD-083S	3/8 ODF	5.43	2.50	6.2	5.9	3.9	12
20116	MLD-162	1/4 SAE	6.58	2.50	2.1	2.1	1.3	12
20117	MLD-162S	1/4 ODF	6.02	2.50	3.1	3.0	1.9	12
20118	MLD-163	3/8 SAE	6.89	2.50	5.1	4.9	3.2	12
20119	MLD-163S	3/8 ODF	6.22	2.50	6.4	6.2	4.0	12
20120	MLD-164	1/2 SAE	7.13	2.50	8.8	8.4	5.5	12
20121	MLD-164S	1/2 ODF	6.27	2.50	9.2	8.8	5.7	12
20123	MLD-165S	5/8 ODF	6.54	2.50	15.3	14.6	9.5	6
20125	MLD-303S	3/8 ODF	8.90	3.00	7.5	7.2	4.7	6
20126	MLD-304	1/2 SAE	9.80	3.00	9.9	9.5	6.2	6
20127	MLD-304S	1/2 ODF	8.94	3.00	12.3	11.8	7.7	6
20128	MLD-305	5/8 SAE	10.18	3.00	12.6	12.1	7.9	6
20129	MLD-305S	5/8 ODF	9.21	3.00	16.8	16.1	10.5	6
20130	MLD-306S	3/4 ODF	9.63	3.00	18.1	17.4	11.3	6
20131	MLD-307S	7/8 ODF	9.80	3.00	19.0	18.2	11.8	6

¹ All ratings in accordance with ARI standard 710-04, 86°F Liquid Refrigerant Temperature, 5°F Saturated Temperature
4.0 lbs./min./ton for R-134a, 2.9 lbs./min./ton for R-22, 4.0 lbs./min./ton for R-404A/R-507